

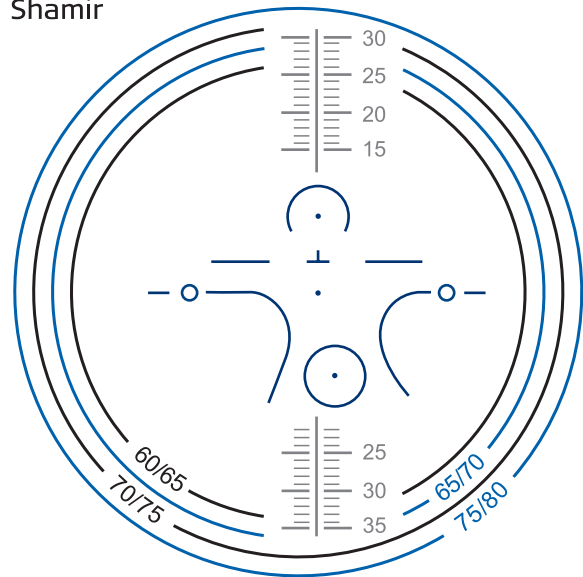

Shamir



Shamir

Piccolo™

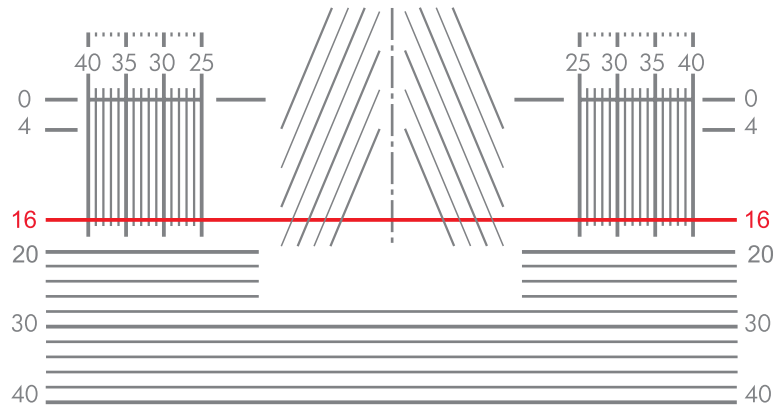



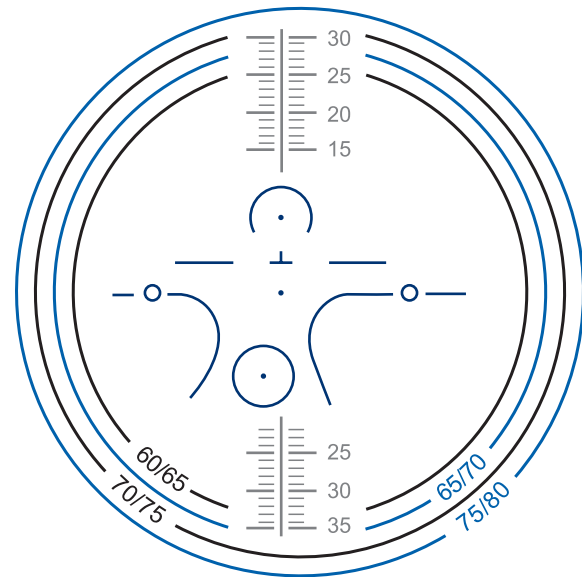

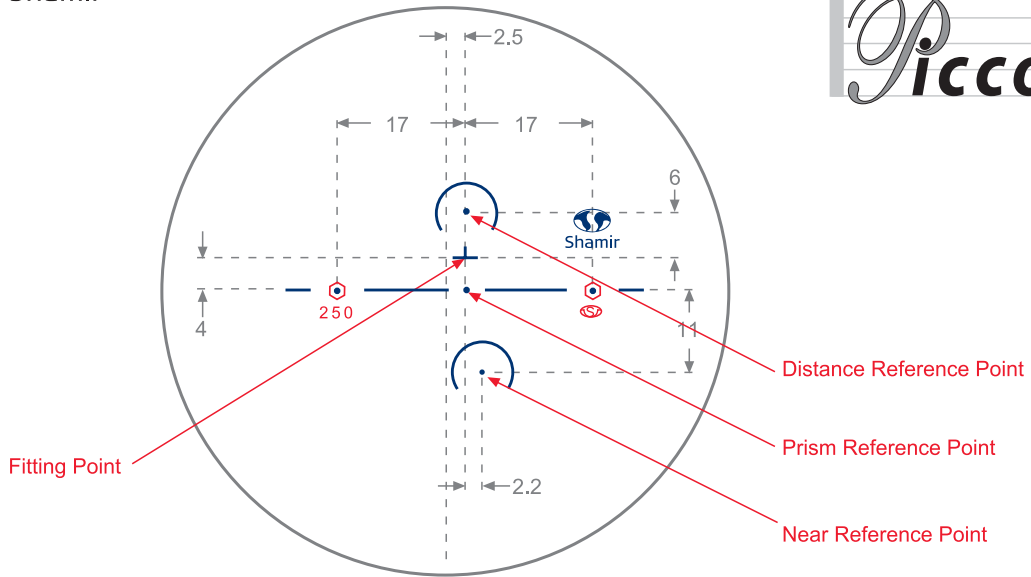



Minimum Fitting Height 16mm





Ink Marking: Blue
Invisible Marking: Red

Minimum Fitting Height 16mm

Material	Invisible Marking
CR-39 1.5	250 
Transitions V 1.5	250 
Polycarbonate 1.59	250  PC
SuperLite™ 1.6	250  H
SuperLite 1.6 Transitions V	250  H
SuperLite 1.67	250  67
SuperLite 1.67 Transitions V	250  67
Glass 1.523	250 
Glass 1.523	250  TD